

# MULTI-AXIS MAST LIFTS

## EXTENDED REACH Y-AXIS

- Units are equipped with a double scissor mechanism to provide up to 10 ft. 4 in. of travel for a maximum 14 ft. reach from booth wall. Retracted dimension is 3'-8" from booth wall.
- Operator platform is 21" deep X 48" wide with a capacity of 300#.
- Allows one operator to paint entire end of product.

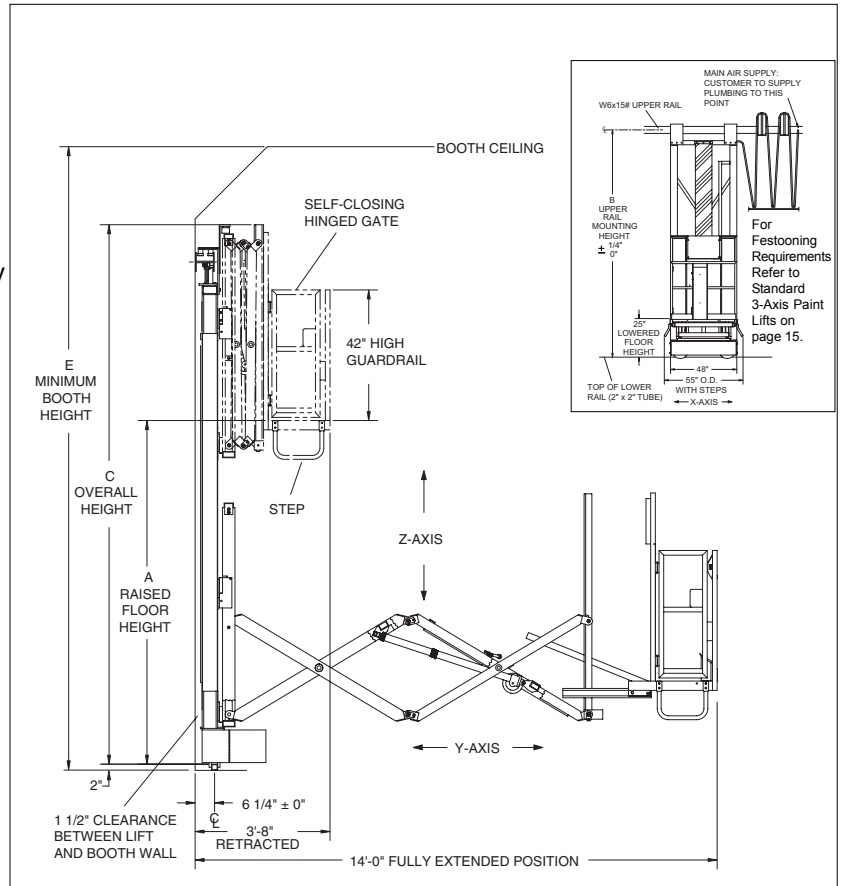

STANDARD MODEL	A	B	C	D	E	F
LP2-814	8'-0"	12'-3"	13'-3"	16'-3"	15'-0"	17'-0"
LP2-914	9'-0"	13'-3"	14'-3"	17'-3"	16'-0"	18'-0"
LP2-104	10'-0"	14'-3"	15'-3"	18'-3"	17'-0"	19'-0"
LP2-1114	11'-0"	15'-3"	16'-3"	19'-3"	18'-0"	20'-0"
LP2-1214	12'-0"	16'-3"	17'-3"	20'-3"	19'-0"	21'-0"
LP2-1314	13'-0"	17'-3"	18'-3"	21'-3"	20'-0"	22'-0"
LP2-1414	14'-0"	18'-3"	19'-3"	22'-3"	21'-0"	23'-0"
LP2-1514	15'-0"	19'-3"	20'-3"	23'-3"	22'-0"	24'-0"
LP2-1614*	16'-0"	20'-3"	21'-3"	24'-3"	23'-0"	25'-0"
LP2-1714*	17'-0"	21'-3"	22'-3"	25'-3"	24'-0"	26'-0"
LP2-1814*	18'-0"	22'-3"	23'-3"	26'-3"	25'-0"	27'-0"
LP2-1914*	19'-0"	23'-3"	24'-3"	27'-3"	26'-0"	28'-0"
LP2-2014*	20'-0"	24'-3"	25'-3"	28'-3"	27'-0"	29'-0"

Dimensions are from top of lower rail.  
 Change prefix LP2 to LP4 for 4th Axis Inside Descent Lift.  
 \*All Extended Reach models over 16 ft. and all 4th Axis models have a 6' 8" base.

## 4TH AXIS INSIDE DESCENT

- This configuration allows for convenient painting of the inside of large products such as truck dump bodies or railroad cars.
- 4th axis movement is controlled by a rotary ballscrew and provides travel speeds of approximately 15 FPM.
- Equipped with same control and safety features as standard LP2 lifts.

See page 15 for Installation Kit Numbers.  
 See Page 17 for Option Numbers & Descriptions.

Note: Model selected should not exceed the inside height of booth. For calculation take the raised floor height (Dimension A) of the lift plus an additional 7' for personnel.  
 • All models meet applicable OSHA/ANSI Standards as interpreted by LPI, Inc. •

