

# AIR/HYDRAULIC SCISSOR LIFTS

## COMPACT, PNEUMATIC ELEVATING WORK TABLES/PLATFORMS

LPI Inc. has introduced a **NEW** work platform/worktable for light or medium duty applications.

The EWP-4 personnel lift is ideal for areas with limited space. This compact, economical, air operated scissor lift provides a safer alternative to ladders or scaffold and is an ideal solution for paint booths as narrow as 14 ft. or other hazardous environments. The unit features a space saving lightweight design, including a 20" wide deck, with a non-slip floor surface. The platform has a lowered height of 10" and a maximum raised height of 46", providing a working height of approximately 10 ft.

The unit is also available as a worktable, EWT-4, providing a 20 X 66" work surface and up to 1000 lb. load capacity. Both the work platform and worktable are equipped with air controls for safe and easy operation.

### INCREASED SAFETY

- Reduces fatigue and minimizes excessive movement associated with manual lifting.

### AFFORDABLE

- Operates off compressed air source (not included), requires 8 SCFM at 100 psi.

### OPTIONS AVAILABLE

- 203-0903: Caster Kit
- 203-0904: Bolt Down Kit
- 203-0905: T-Bar Transport Kit
- 203-0906: Access Ramp Kit
- 960-0097-06000: Non-Slip Surface: EWT-4 (Standard on EWP-4)
- 222-5759: Bumpers

### APPLICATIONS

- Maintenance
- Material Handling
- Manufacturing
- Paint Booth

### LIFT TRAVEL SPEED

Up: 5 F.P.M.  
Down: 15 F.P.M.

### SPECIAL OPTIONS

- Call for details on:
- Rail guided systems



### CASTER KIT AND T-BAR TRANSPORT OPTIONS



203-0903: Caster Kit



203-0905: T-Bar Transport Kit

MODEL #	MAX. WORKING HEIGHT	RAISED FLOOR HEIGHT	LOWERED FLOOR HEIGHT	PLAT-FORM LENGTH	PLAT-FORM WIDTH	PLAT-FORM CAPACITY	OVERALL LENGTH	OVERALL WIDTH	SHIPPING WEIGHT
EWT-4	10'	46"	10"	66"	20"	1000#	66"	20"	330
EWP-4	10'	46"	10"	66"	20"	500#	66"	25"	380

All work platforms, unless indicated otherwise, are slab type machines and should only be raised on hard, flat, level surfaces.

View our website - [www.lpi-inc.com](http://www.lpi-inc.com) for more information on the Elevating Work Table or any of our other products. Our engineers will work closely with you to develop a system designed specifically to your application.



LPI® is a registered trademark of LPI, Inc. 2004

# AIR/HYDRAULIC SCISSOR LIFTS

## STATIONARY/MANUALLY PROPELLED



- Pneumatic/hydraulic power. Safe for use in paint booths and other hazardous locations.
- AC and DC power options.
- Minimal installation - quick and easy connection to air source, 1/2" NPT
- Available in manually positioned roll-around (Model LPSMT) or stationary version (Model LPSM).
- Approx. 15 F.P.M. lift speed.
- Custom product conversion available upon request.

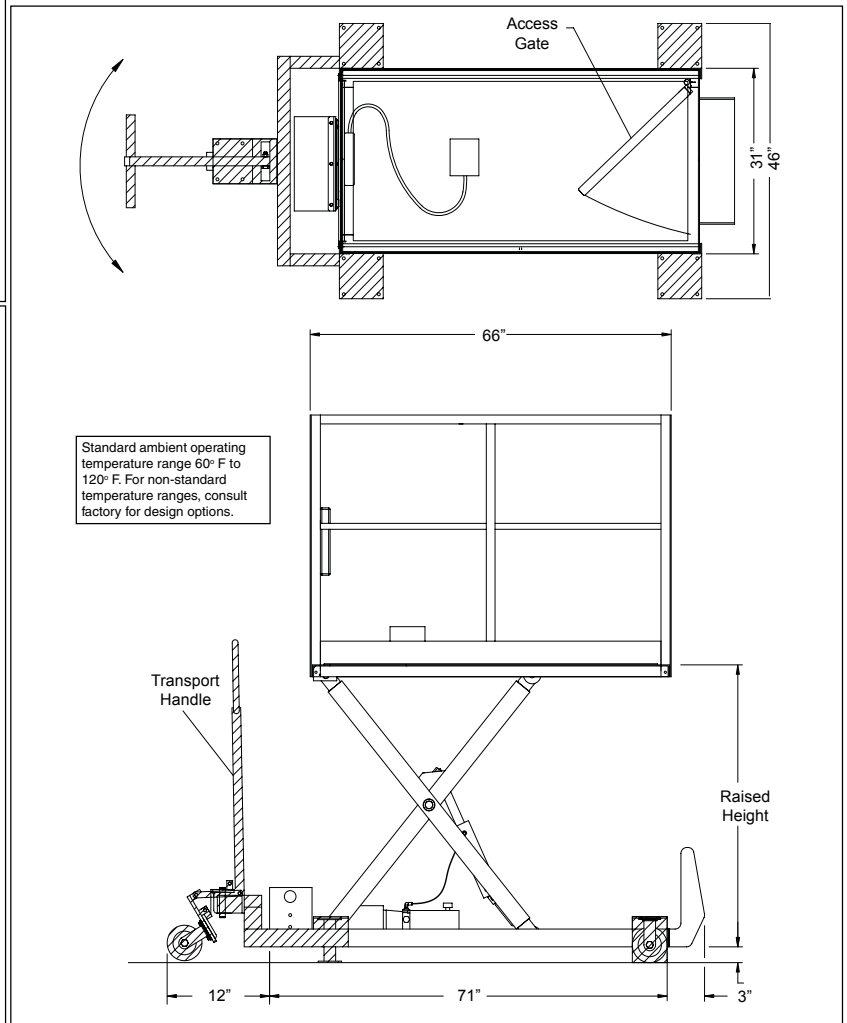

### ALL MODELS INCLUDE

- Fixed hand control with Emergency Stop
- 42" high guard rail with a self-closing gate
- Filter/Regulator/Lubricator
- OSHA approved shut off/lockout valve
- Velocity check valve to prevent descent of platform if there is a hose rupture or loss of system pressure
- 3/8" NPT auxiliary air supply in operator platform
- Lift cylinder rod cover to prevent overspray buildup
- Operator platform capacity 500#.
- 15 F.P.M. Lift Speed.
- Unit requires clean dry air supply of 50 SCFM at 100 PSI.
- Pneumatic/hydraulic power, inherently safe in painting/finishing atmospheres.
- Minimal installation - Quick and easy connection to air source, 1/2" NPT.

### OPTIONAL

Foot control for vertical travel ..... P/N 203-0259  
 Accordion bellows (not available on LPSMT models).  
 (LPSM-48) ..... P/N 222-5091-48  
 (LPSM-96) ..... P/N 222-5091-96  
 (LPSM-144) ..... P/N 222-5091-144

MODEL #	MAX. WORKING HEIGHT	RAISED FLOOR HEIGHT	LOWERED FLOOR HEIGHT	PLAT-FORM LENGTH	PLAT-FORM WIDTH	OVERALL LENGTH	OVERALL WIDTH	SHIPPING WEIGHT
LPSM-48*	121"	49"	10½"	66"	31"	74"	31"	750
LPSM-96*	164"	92"	16"	66"	31"	74"	31"	950
LPSM-144*	212"	140"	18"	66"	31"	74"	31"	1250
LPSMT-48	124"	52"	13½"	66"	31"	86"	46"	800
LPSMT-96	167"	95"	19"	66"	31"	86"	46"	1000
LPSMT-144	215"	143"	21"	66"	31"	86"	46"	1300

**LPSMT Models Include:**  
 An easy to use Transport Handle Kit (components shaded in gray) for mobility and positioning between work areas. Transport Handle Kit includes: 6" rigid casters and a pull-down handle with retractable steering wheel for maneuverability. Also included is a safety switch to prevent the operator platform from being raised with transport handle in "transport" position.

\*Unit must be bolted to floor

SLAB TYPE MACHINE SHOULD ONLY BE RAISED ON A HARD FLAT LEVEL SURFACE.

• All models meet applicable OSHA/ANSI Standards as interpreted by LPI, Inc. •