

Dual Mast Mobile Work Platform for Aircraft MRO

Designed for aircraft and aerospace MRO environments, this dual mast work platform provides safe, flexible access for maintenance, inspection, and assembly operations along large airframes. The mobile system supports changing aircraft geometries and workflows while maintaining stable, consistent access at height. Well suited for dynamic production and maintenance settings, it improves reach, efficiency, and operator safety while reducing reliance on ladders and scaffolding.

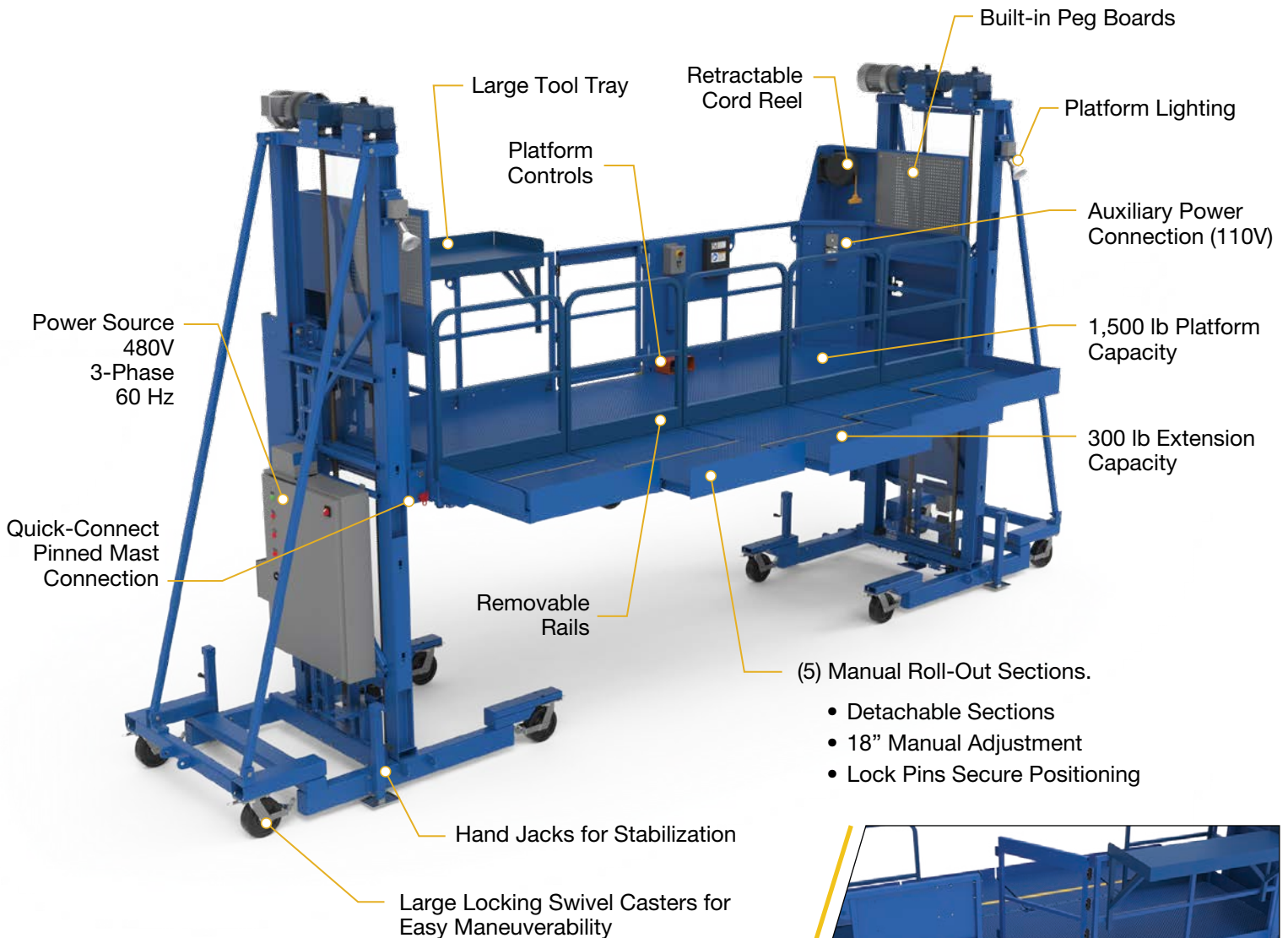

Adaptable positioning in dynamic production and MRO environments!



Dual Mast Mobile Work Platform for Aircraft MRO



The platform and mast assemblies easily disconnect, allowing components to be positioned in smaller areas for storage or transport.

This platform can be customized to support unique equipment, access requirements, and work processes.

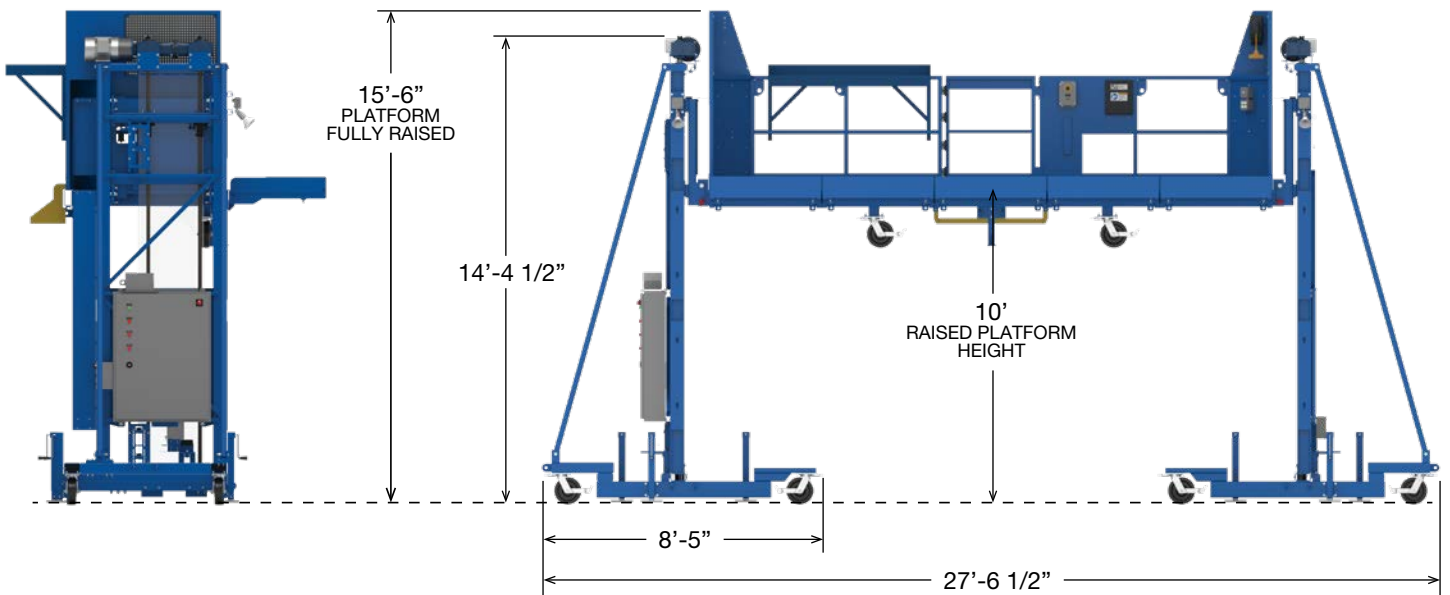
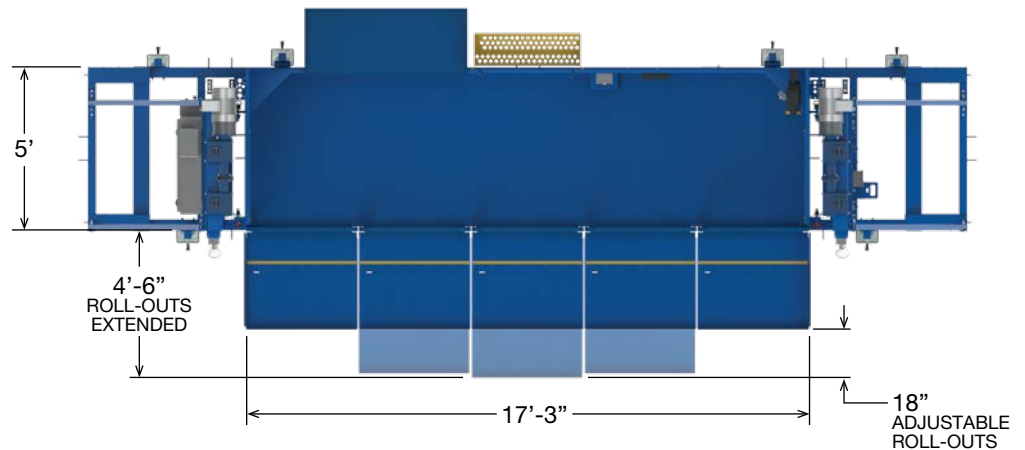

LPI products help promote a safe and ergonomic work environment, which contributes to improved worker productivity. Due to continuous product improvements, we reserve the right to make specification and/or equipment changes without prior notification.