

VL Series

Vestibule Access Lift for Quick Color Change Powder Coating Booths



The Vestibule Series Lift is the ideal turnkey solution for vestibule touch-up areas across any powder coating operation. Designed with a compact footprint, the VL system provides complete access to the workpiece for manual touch-ups, whether in Quick Color Change systems or standard powder coating booths. By efficiently moving the operator to the work surface, the lift ensures consistent coating quality, minimizes downtime, and enhances productivity in both high-throughput and general finishing environments.

Standard Features

- › 36"x48" -or- 36"x60" platform
- › Entry gate on left, right or both sides
- › Bolt-on removable front guardrail
- › Fall restraint anchor points
- › Grated platform floor

Available Options

- › Breathing air connection
- › Platform mounted tool tray
- › Conveyor interlock components
- › Consult factory for additional options and corporate branded colors

Safety & Productivity Benefits

- › Integrated fall protection via ANSI standard guardrails and self-closing gate.
- › Boosts productivity by allowing operators to reposition without ever leaving the platform.
- › Suitable for use in hazardous locations where combustible dust or vapors may be present.

Common Applications / Uses

- › Quick color change powder coating vestibule areas for product touch-ups.
- › Powder systems for batch coating access or inspection for tall parts.
- › Vertical platform for any application not requiring X or Y axis movement.
- › Perfect for tall, linear part inspection.
- › Continuous vertical seam welding.



VL Series

Vestibule Access Lift for Quick Color Change Powder Coating Booths

The VL Series lift is designed to meet applicable ANSI Standards for Mobile Elevating Work Platforms.

Series	A (Ft.-in.)
VL6	5'-10"
VL7	6'-10"
VL8	7'-10"
VL9	8'-10"
VL10	9'-10"

Higher platform travel available upon request. May require additional connection point at top of mast.

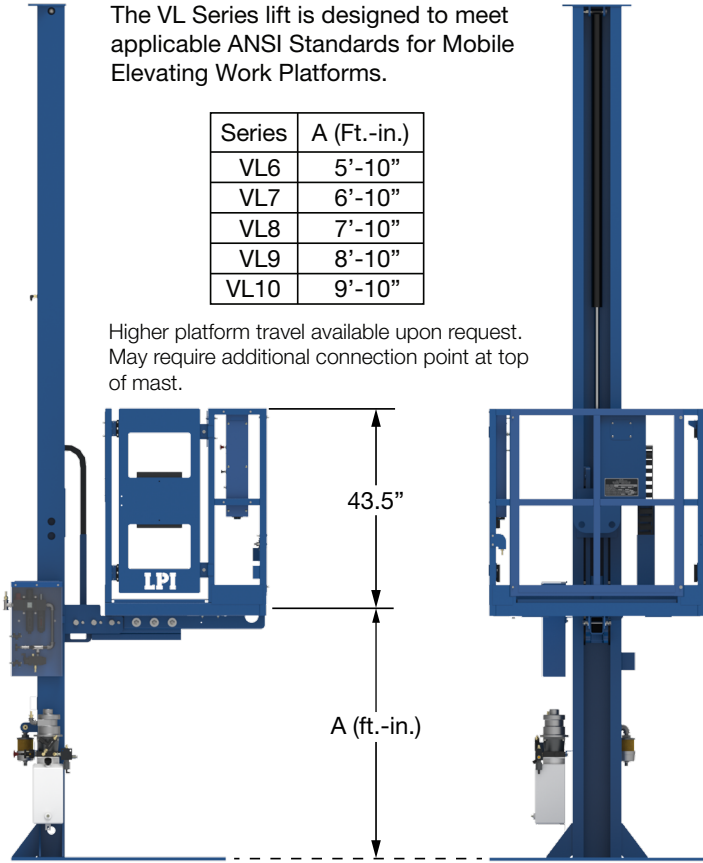

General Specifications

- > Pneumatic-hydraulic power
- > Air requirements:
50scfm @ 90psi / 40°F dew point
- > Equipped with air filter/regulator/lubricator
- > Platform capacity: 300lbs
- > Vertical travel speed: Up to 15ft./min.
- > Platform controls include:
Up/Down - Emergency Stop - Emergency descent

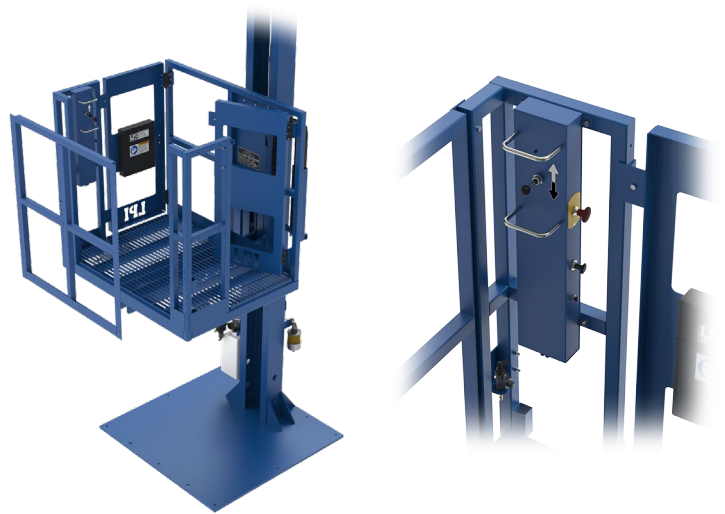

LPI products help promote a safe and ergonomic work environment which contributes to improved worker productivity. Due to continuous product improvements, we reserve the right to make specification and/or equipment changes without prior notification.

New Equipment Financing Available

LPI Lift Systems is proud to provide new equipment financing options through [NewLane Finance](#). Purchasing your equipment is **easy, fast and convenient** when you choose the **custom payment option that's right for your business**.

A better lending experience through 4 easy steps.

1

Apply in minutes

2

Get a decision in hours

3

Sign electronic documents

4

Receive your equipment

Trying to accommodate your budget? Ask about our deferral and step payment plans.

Jenny Wood - Senior Business Development Account Manager | jwood@newlanefinance.com | (320) 761-3652
www.newlanefinance.com | 123 S. Broad Street, 17th Fl, Philadelphia, PA 19109