



# **Hazard-Rated Pneumatic Lift Systems For Paint, Blast & Other Industrial Applications**

## **Standard Series Product Catalog**

# TABLE OF CONTENTS

	<u>Pg.</u>
Application Guide .....	1
Principles of Operation .....	2
Paint Lifts vs. Blast Lifts (Differences) .....	3
<b>PL Series</b>   Standard 3-Axis Lift .....	4,5
<b>PL Series</b>   Standard Extended Reach 3-Axis Lift .....	6,7
<b>PL Series</b>   Standard Options .....	8,9
<b>BL Series</b>   Standard 3-Axis Blast Lift .....	10,11
<b>BL Series</b>   Standard Extended Reach 3-Axis Blast Lift .....	12,13
<b>BOOST Series</b>   Self-Propelled Elevating Work Platform .....	14,15
<b>VL Series</b>   Single Axis Vertical Mast Lift .....	16,17
<b>SPHR Series</b>   Rail-Guided Scissor Platform .....	18,19
<b>WCL Series</b>   Portable Scissor Platform with Roll-outs .....	20,21

## **ADDITIONAL PRODUCTS & SERVICES**

Scissor & Custom Lift Solutions .....	22
Warranty, Service & Maintenance .....	23

## **ABOUT LPI, INC**

LPI Lift Systems is a U.S.-based manufacturer of standard and custom-engineered work platforms, fall protection systems, and personnel lifts designed for demanding industrial environments. With more than four decades of experience, LPI combines in-house engineering expertise with precision manufacturing to deliver reliable access solutions tailored to a wide range of industries and specialized applications.

Our equipment is built to improve safety, ergonomics, and workflow efficiency, helping reduce workplace injuries while supporting consistent productivity on the production floor.

All LPI lifts are designed and manufactured in the United States and comply with applicable OSHA and ANSI standards.

**Challenge us with your application!**  
**[www.lpi-inc.com](http://www.lpi-inc.com)**

## VERTICAL MAST SYSTEMS

Vertical mast lift systems are lifts where the vertical travel happens within a column (mast) either attached to a structure, or freestanding. Ideal for large work areas where 3-dimensional (axis) movement and positioning enhances the process.

### Common Applications

- Painting
- Powder Coating
- Surface Prep
- Blasting Booths / Rooms
- Wash Rooms
- Material Handling
- Maintenance Areas
- Assembly Areas
- Welding

LPI Lift Systems are designed for any application where operator safety and fall prevention is essential!



## MAJOR INDUSTRIES

Many industries have manufacturing and production processes that utilize personnel lifts. LPI Lift Systems serves all of them and continues to provide enhanced personnel safety to new industries worldwide.

- Aircraft & Aerospace
- Construction Equipment
- Agricultural Equipment
- Rail Car & Locomotive Manufacturing
- Trucks & Recreational Vehicles
- Light Rail & Bus Manufacturing
- Military Equipment
- Transit Authorities
- Modular Home Construction
- Electrical Power & Distribution



# PRINCIPLES OF OPERATION

## (MOVEMENT BASICS)

Standard axis lifts are designed to move in 3-Axis travel ( X, Y, Z).

The three axes of movement are:

**X-Axis** Horizontal movement of the entire lift, lengthwise in a booth or along a structure.

**Y-Axis** Horizontal movement of the operator platform in and out from the back of the lift.

**Z-Axis** Vertical travel of the operator platform up and down on the lift mast.

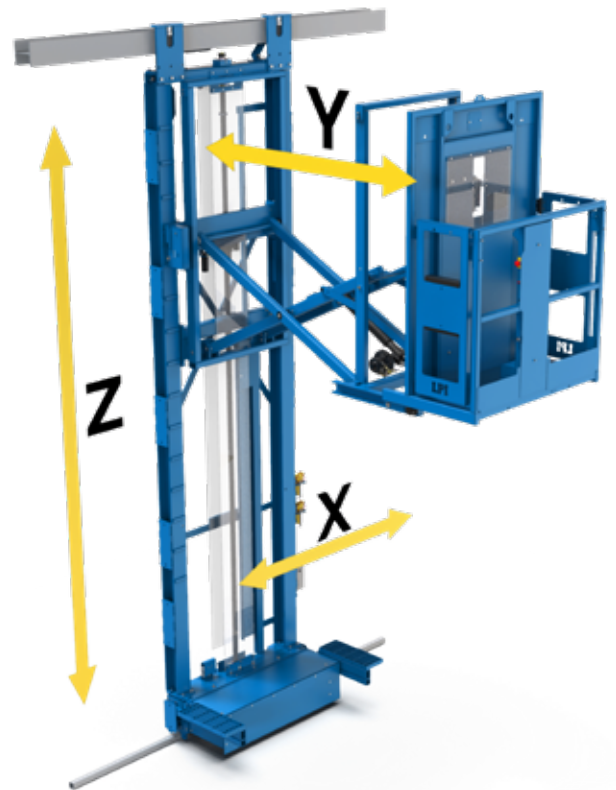

- Lift travels on a guide rail system with a lower rail anchored to the floor and an upper rail mounted to the wall of the booth or other structure.
- Lift is controlled by the operator from a control console located in the front of the platform. This allows the worker to face forward and observe the area as they move the lift.
- Properly maintained, LPI Lift Systems will provide many years of trouble free operation while increasing the safety and productivity of your workers.

## VERTICAL MAST SYSTEMS

- Applications include wash, prep and paint, to metal blasting, welding and fabrication. Great for any area where ergonomic positioning and fall protection are needed.
- Combinations of pneumatic, hydraulic or mechanical drives to suit your application.
- Standard lift models with working heights ranging from 6' to 22'.
- Lifts are fully assembled and tested prior to shipping making them ready for operation when installed.
- Operator platforms can be configured with options to fit your process needs.
- Units are designed for high productivity environments and integration into manufacturing processes.
- Lifts are designed to provide a safer working solution for working at heights which increases productivity and worker satisfaction.
- Custom or modified lift systems can be designed and fabricated for areas where standard models may not be the solution.

# PAINT LIFTS vs BLAST LIFTS

## (COMMON FEATURES / DIFFERENCES)

### COMMON FEATURES

- Railings on operator platform include self-closing, self-latching entry/exit gates
- Forward facing operator controls allow operator full view of work area when repositioning
- Auxiliary, unooled air supply connection in operator platform
- Platform entry steps mounted on base of lift
- Platforms and movement can be customized to specifically fit your application
- 3-Axis (X,Y,Z) movement for precise positioning of platform
- Safety harness restraint points in operator platform

### DIFFERENCES

#### PAINT LIFTS

Paint booth applications

Multiple operator platform options to satisfy application process needs

Spring applied, air released vertical movement (Z-axis) brake

Open mast design with overspray covers

Vertical (Z-axis) drive is air motor/mechanical powered

Standard 21"x48" platform with multiple options available

Filters, regulators & lubricators in base of lift

Solid safety plate flooring in operator platform

Options for Wash and Welding applications



#### BLAST LIFTS

Blast, Grit and Powder applications

Inertial chain brake on vertical (Z-axis) drive systems

Vertical (Z-axis) drive is air/hydraulic powered with lifting cables

Sealed mast system with removable covers

Can be designed for vertical heights in excess of 40'

Standard 30"x48" platform

Open grating flooring in operator platform

Heavier gauge steel to withstand abrasive and harsh environments

Filters, regulators & lubricators enclosed in cabinet on side of lift



## 3-Axis Pneumatic Paint Lift (Standard)

Designed to enhance the productivity and ergonomics for operators. The pneumatically powered lifts are an ideal accessory in hazardous environments and many other manufacturing process or production areas.



### GENERAL INFO

- Raised platform height: Up to 22'
- Retracted dimension: 3' (minimum)
- Extended dimension: 8' or 10' (per model)
- Operator platform capacity: 500 lbs.
- Pneumatic/mechanical power unit
- Includes in-line Filter/Regulator/Lubricator
- Standard platform: 48" wide x 21" deep
- Self-closing/self-latching entry gates

### CONTROLS / CONNECTIONS

- Operator controls on front rail of platform
- Hand controls for Y-Axis, Z-Axis, & E-stop
- Foot control for X-Axis
- Base control to raise and lower platform
- Auxiliary uncoiled air connection in platform
- Lift requires a clean, dry air supply  
(80 scfm @ 100 psi with a 40°F dew point)

### TRAVEL SPEEDS

- X-Axis (left/right): Variable up to 40 fpm
- Y-Axis (in/out): Up to 15 fpm
- Z-Axis (up/down): Up to 15 fpm

Due to continuous product improvement, LPI, Inc. reserves the right to make equipment/specification changes without prior notification.



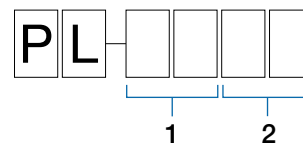
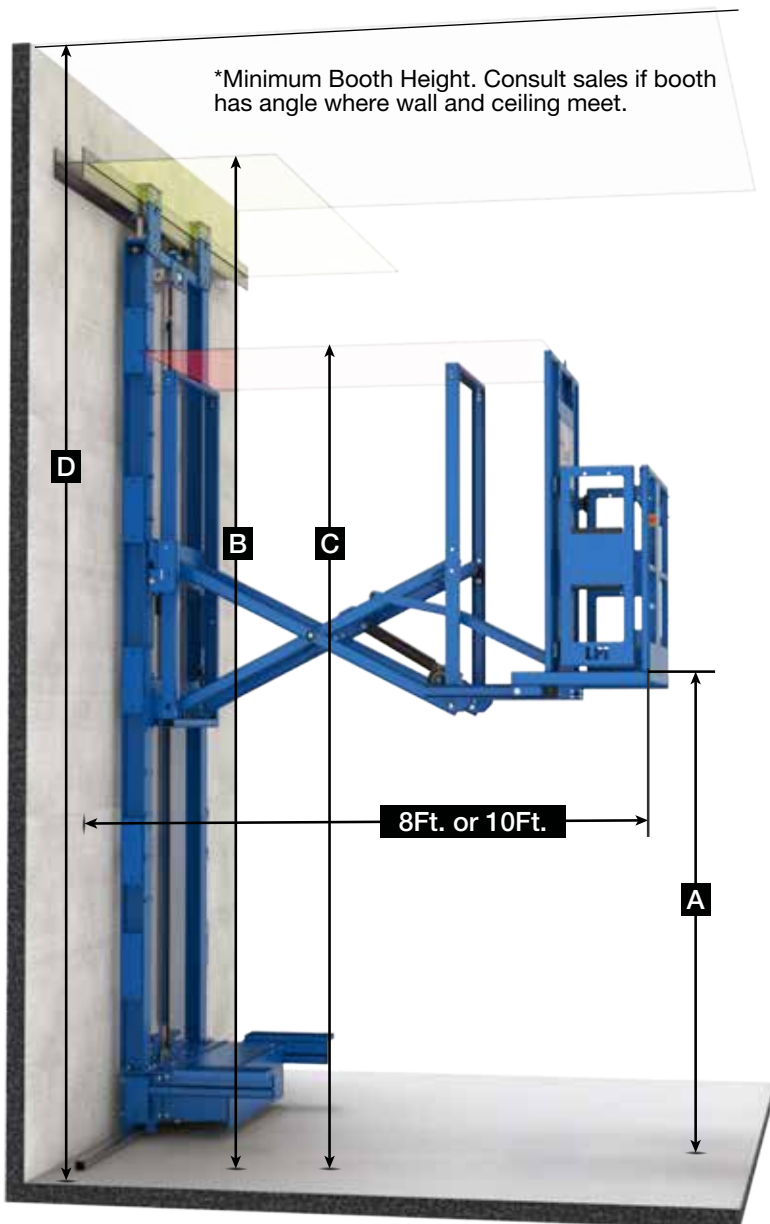

PL Series Standard Configurations		
1	Raised Platform Height (ft.)	06 thru 22 (1ft. increments)
2	Extended Dimension (ft.)	08 (8ft.) 10 (10ft.)

PL Series (Standard Reach Models)				
Model	A	B	C	D
PL-06xx	6'	9'-3"	11'-6"	12'
PL-07xx	7'	10'-3"	12'-6"	13'
PL-08xx	8'	11'-3"	13'-6"	14'
PL-09xx	9'	12'-3"	14'-6"	15'
PL-10xx	10'	13'-3"	15'-6"	16'
PL-11xx	11'	14'-3"	16'-6"	17'
PL-12xx	12'	15'-3"	17'-6"	18'
PL-13xx	13'	16'-3"	18'-6"	19'
PL-14xx	14'	17'-3"	19'-6"	20'
PL-15xx	15'	18'-3"	20'-6"	21'
PL-16xx	16'	19'-3"	21'-6"	22'
PL-17xx	17'	20'-3"	22'-6"	23'
PL-18xx	18'	21'-3"	23'-6"	24'
PL-19xx	19'	22'-3"	24'-6"	25'
PL-20xx	20'	23'-3"	25'-6"	26'
PL-21xx	21'	24'-3"	26'-6"	27'
PL-22xx	22'	25'-3"	27'-6"	28'

- A: Raised Platform Height
- B: Centerline of Upper Rail
- C: Overall Max. Lift Height
- D\*: Min. Booth Height

Note: All vertical dimensions shown are from the top of the lower rail

Dimensions shown are nominal. Actual dimensions may vary and are presented with engineering drawings.



## 3-Axis Pneumatic Lift (Extended Reach)

Extended reach lifts are similar in design to the standard PL lifts, but are designed for booths or bays that are wider than normal, to accommodate large products or multiple products at the same time. Extended reach design allows the front of the platform to reach up to 14' out from the booth wall.



### GENERAL INFO

- Raised platform height: Up to 21'
- Retracted dimension: 3'-8"
- Extended dimension: 14'
- Operator platform capacity: 400 lbs.
- Pneumatic/mechanical power unit
- Includes in-line Filter/Regulator/Lubricator
- Standard platform: 48" wide x 21" deep
- Self-closing/self-latching entry gates

### CONTROLS / CONNECTIONS

- Operator controls on front rail of platform
- Hand controls for Y-Axis, Z-Axis, & E-stop
- Foot control for X-Axis
- Base control to raise and lower platform
- Auxiliary unooled air connection in platform
- Lift requires a clean, dry air supply  
(80 scfm @ 100 psi with a 40°F dew point)

### TRAVEL SPEEDS

- X-Axis (left/right): Variable up to 40 fpm
- Y-Axis (in/out): Up to 15 fpm
- Z-Axis (up/down): Up to 15 fpm

Due to continuous product improvement, LPI, Inc. reserves the right to make equipment/specification changes without prior notification.



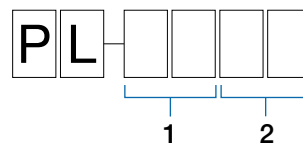
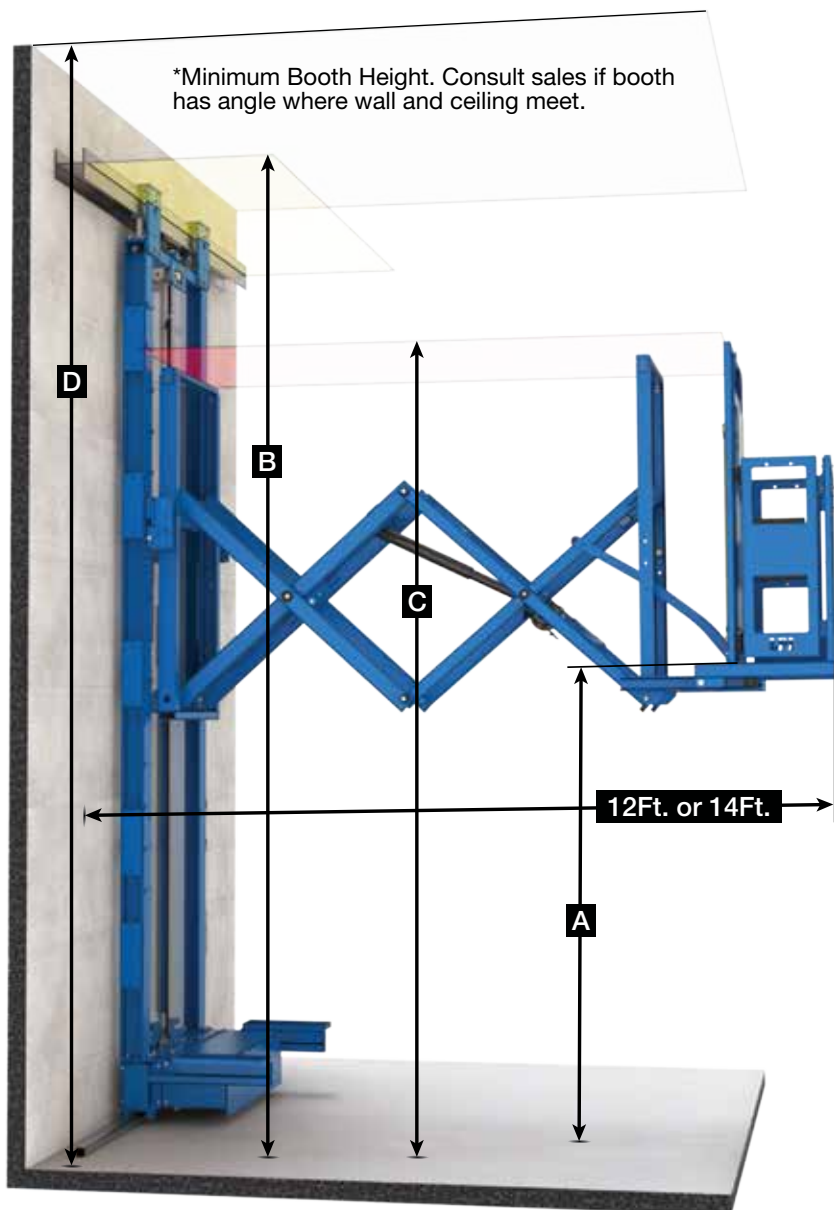

PL Series Standard Configurations		
1	Raised Platform Height (ft.)	06 thru 21 (1ft. increments)
2	Extended Dimension (ft.)	12 (12ft.) 14 (14ft.)

PL Series (Extended Reach Models)				
Model	A	B	C	D
PL-06xx	6'	10'-3"	11'-6"	12'
PL-07xx	7'	11'-3"	12'-6"	13'
PL-08xx	8'	12'-3"	13'-6"	14'
PL-09xx	9'	13'-3"	14'-6"	15'
PL-10xx	10'	14'-3"	15'-6"	16'
PL-11xx	11'	15'-3"	16'-6"	17'
PL-12xx	12'	16'-3"	17'-6"	18'
PL-13xx	13'	17'-3"	18'-6"	19'
PL-14xx	14'	18'-3"	19'-6"	20'
PL-15xx	15'	19'-3"	20'-6"	21'
PL-16xx	16'	20'-3"	21'-6"	22'
PL-17xx	17'	21'-3"	22'-6"	23'
PL-18xx	18'	22'-3"	23'-6"	24'
PL-19xx	19'	23'-3"	24'-6"	25'
PL-20xx	20'	24'-3"	25'-6"	26'
PL-21xx	21'	25'-3"	26'-6"	27'

- A: Raised Platform Height
- B: Centerline of Upper Rail
- C: Overall Max. Lift Height
- D\*: Min. Booth Height

Note: All vertical dimensions shown are from the top of the lower rail

Dimensions shown are nominal. Actual dimensions may vary and are presented with engineering drawings.



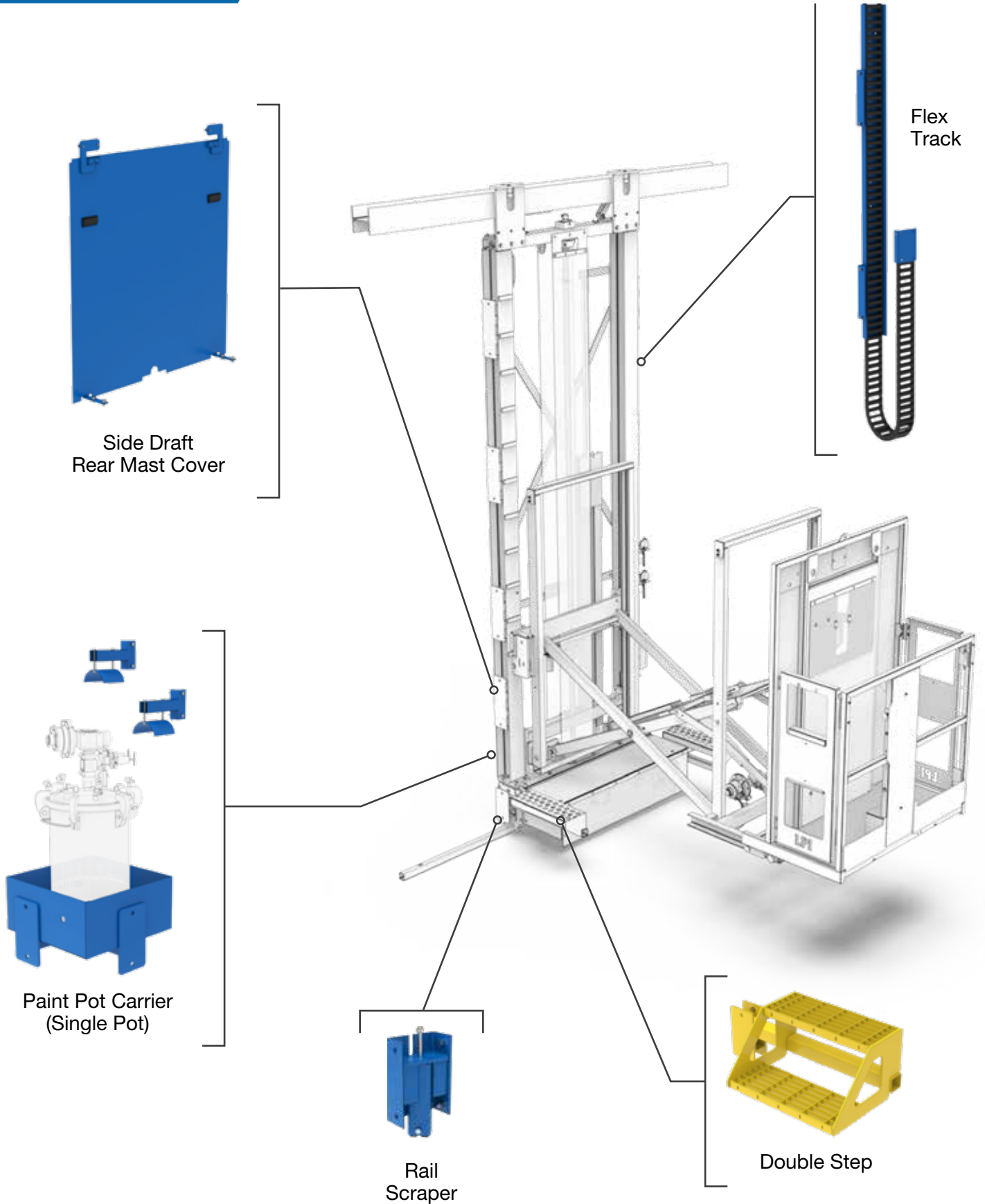

## Standard Options

# PL SERIES

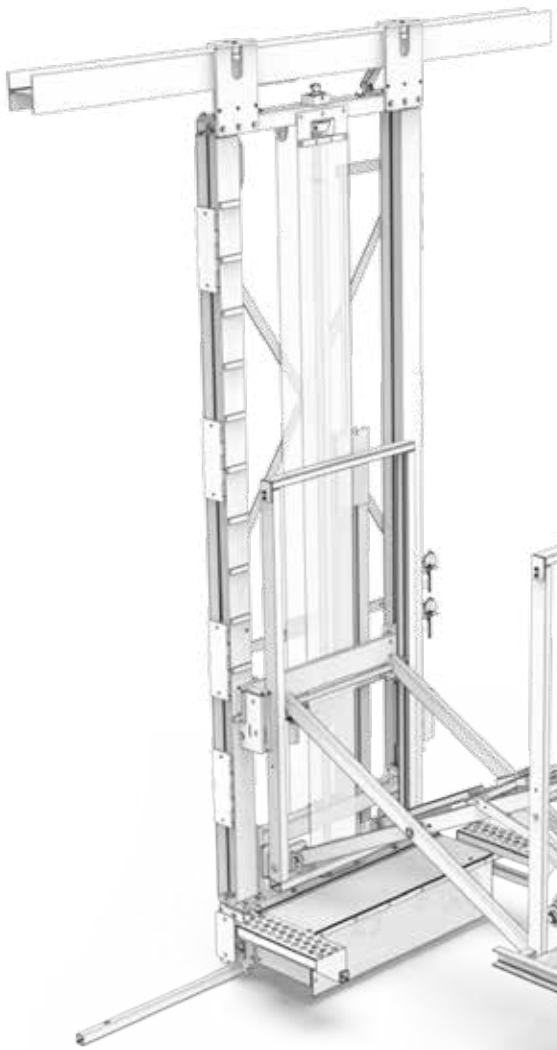

Breathing Air Connection



Platform Depth Sizes:  
21" / 24"



Tip-Out Front Rail

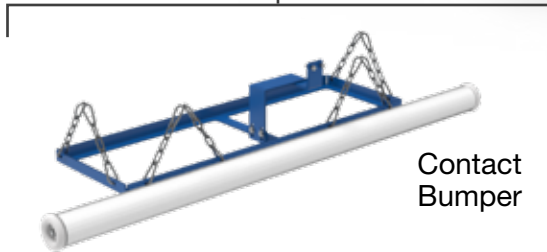

Contact Bumper

## Additional Options and Customizations

### Wash Kit

Upgraded components make the lift suitable for use in pre-treatment and wash booths

### High Solids Kit

Upgraded components make the lift suitable for use in high solids/heavy coating spray booths

### Lift Customizations

PL Series lifts can be configured with application-specific platform layouts, motion ranges, controls, and safety features to support unique paint, prep, and finishing requirements. Contact our team to discuss your application and available configuration options.

## 3-Axis Pneumatic Blast Lift (Standard)

Designed to withstand the harsh environment of grit, sand, and shot blast booths. Featuring sealed components and lift mast along with heavy gauge material, the lifts can replace ladders providing increased safety and productivity. This design is also used for extended height applications where platform heights can be in excess of 40'.



### GENERAL INFO

- Raised platform height: 6' to 21' (standard)
- Retracted dimension: 4' (minimum)
- Extended dimension: 9'
- Operator platform capacity: 500 lbs.
- Sealed mast construction
- Pneumatic/hydraulic power unit
- Includes in-line Filter/Regulator/Lubricator
- Standard platform: 48" wide x 30" deep
- Self-closing/self-latching entry gates
- Blast hose hook to attach hose to platform

### CONTROLS / CONNECTIONS

- Operator controls on front rail of platform
- Hand controls for Y-Axis, Z-Axis, & E-stop
- Foot control for X-Axis
- Base control to raise and lower platform
- Auxiliary uncoiled air connection in platform
- Lift requires a clean, dry air supply  
(80 scfm @ 100 psi with a 40°F dew point)

### TRAVEL SPEEDS

- X-Axis (left/right): Variable up to 40 fpm
- Y-Axis (in/out): Up to 15 fpm
- Z-Axis (up/down): Up to 15 fpm

Due to continuous product improvement, LPI, Inc. reserves the right to make equipment/specification changes without prior notification.



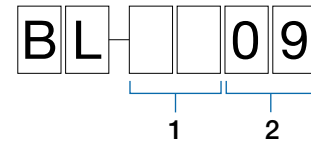
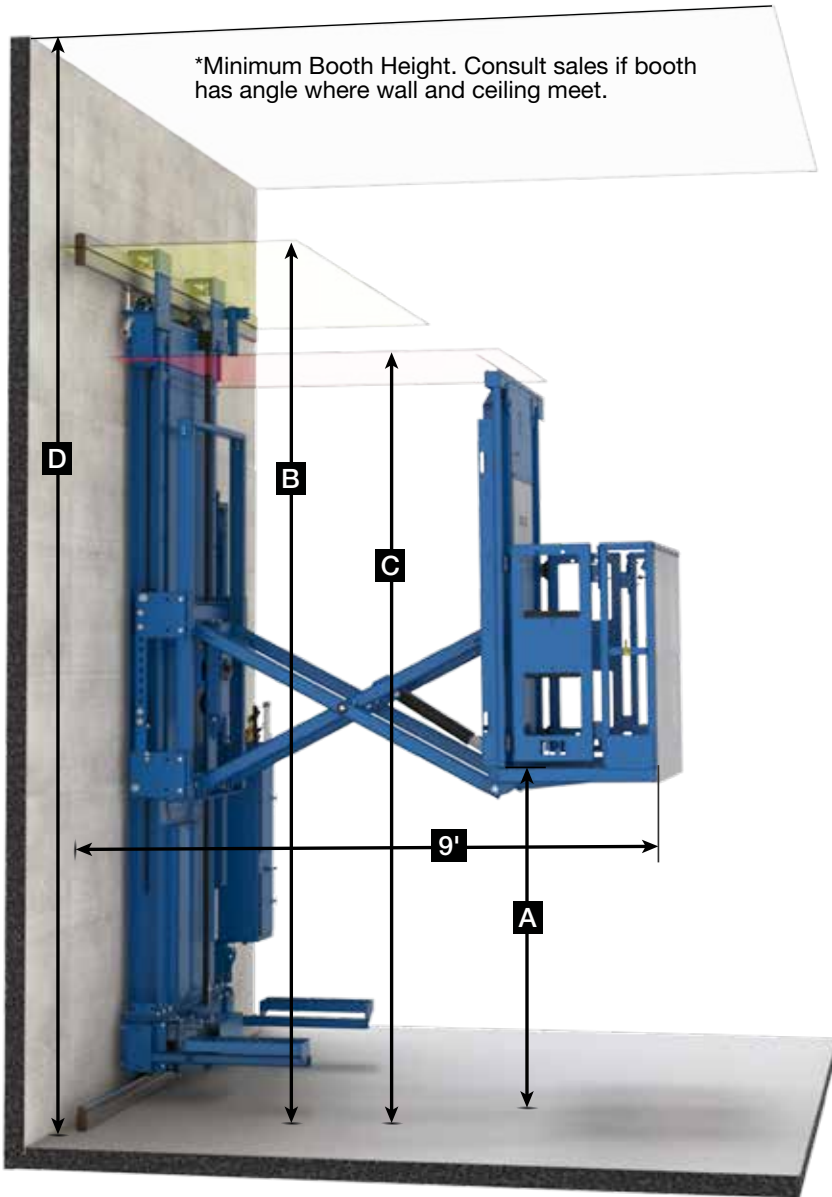

BL Series Standard Configurations		
1	Raised Platform Height (ft.)	06 thru 21 (1ft. increments)
2	Extended Dimension (ft.)	09 (9ft.)

BL Series (Standard Reach Models)				
Model	A	B	C	D
BL-0609	6'	10'-11"	12'-6"	13'
BL-0709	7'	11'-11"	13'-6"	14'
BL-0809	8'	12'-11"	14'-6"	15'
BL-0909	9'	13'-11"	15'-6"	16'
BL-1009	10'	14'-11"	16'-6"	17'
BL-1109	11'	15'-11"	17'-6"	18'
BL-1209	12'	16'-11"	18'-6"	19'
BL-1309	13'	17'-11"	19'-6"	20'
BL-1409	14'	18'-11"	20'-6"	21'
BL-1509	15'	19'-11"	21'-6"	22'
BL-1609	16'	20'-11"	22'-6"	23'
BL-1709	17'	21'-11"	23'-6"	24'
BL-1809	18'	22'-11"	24'-6"	25'
BL-1909	19'	23'-11"	25'-6"	26'
BL-2009	20'	24'-11"	26'-6"	27'
BL-2109	21'	25'-11"	27'-6"	28'

- A: Raised Platform Height
- B: Centerline of Upper Rail
- C: Overall Max. Lift Height
- D\*: Min. Booth Height

*Note: All vertical dimensions shown are from the top of the lower rail*

Dimensions shown are nominal. Actual dimensions may vary and are presented with engineering drawings.



## 3-Axis Pneumatic Blast Lift (Extended Reach)

Designed to withstand the harsh environment of grit, sand, and shot blast booths. Featuring sealed components and lift mast along with heavy duty components, the lifts can replace ladders providing increased safety and productivity. This design can also be used for extended height applications.

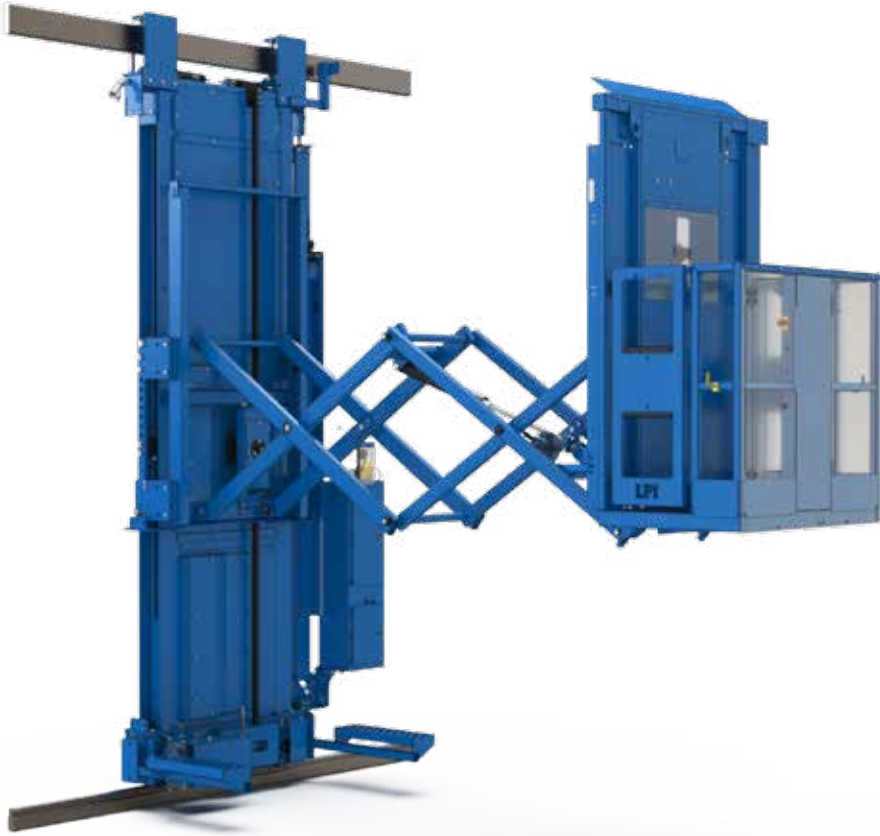

### GENERAL INFO

- Raised platform height: 6' to 21' (standard)
- Retracted dimension: 4'-6" (minimum)
- Extended dimension: 13'-4"
- Operator platform capacity: 400 lbs.
- Sealed mast construction
- Pneumatic/hydraulic power unit
- Includes in-line Filter/Regulator/Lubricator
- Standard platform: 48" wide x 30" deep
- Self-closing/self-latching entry gates
- Blast hose hook to attach hose to platform

### CONTROLS / CONNECTIONS

- Operator controls on front rail of platform
- Hand controls for Y-Axis, Z-Axis, & E-stop
- Foot control for X-Axis
- Base control to raise and lower platform
- Auxiliary uncoiled air connection in platform
- Lift requires a clean, dry air supply  
(80 scfm @ 100 psi with a 40°F dew point)

### TRAVEL SPEEDS

- X-Axis (left/right): Variable up to 40 fpm
- Y-Axis (in/out): Up to 15 fpm
- Z-Axis (up/down): Up to 15 fpm

Due to continuous product improvement, LPI, Inc. reserves the right to make equipment/specification changes without prior notification.



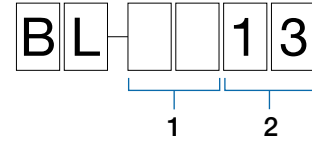
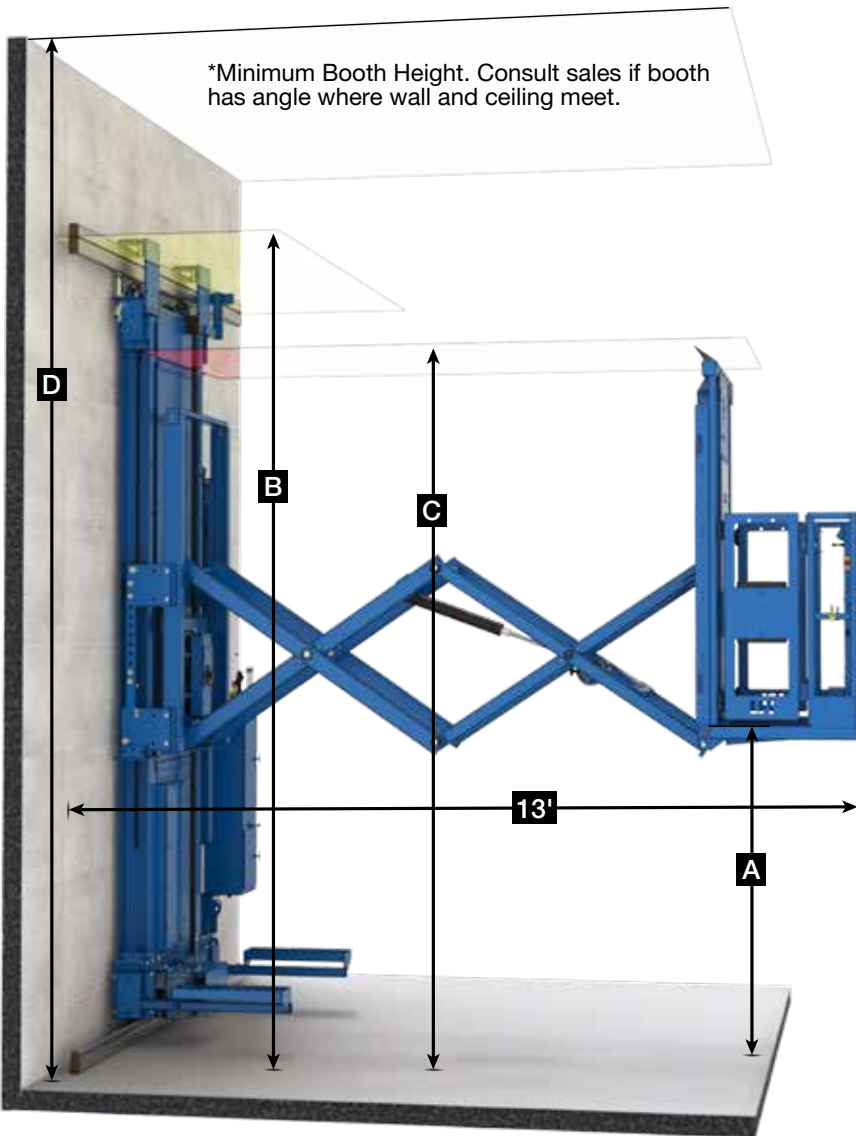

**BL Series Standard Configurations**

1	Raised Platform Height (ft.)	06 thru 21 (1ft. increments)
2	Extended Dimension (ft.)	13 (13ft.)

**BL Series (Extended Reach Models)**

Model	A	B	C	D
BL-0613	6'	10'-11"	12'-6"	13'
BL-0713	7'	11'-11"	13'-6"	14'
BL-0813	8'	12'-11"	14'-6"	15'
BL-0913	9'	13'-11"	15'-6"	16'
BL-1013	10'	14'-11"	16'-6"	17'
BL-1113	11'	15'-11"	17'-6"	18'
BL-1213	12'	16'-11"	18'-6"	19'
BL-1313	13'	17'-11"	19'-6"	20'
BL-1413	14'	18'-11"	20'-6"	21'
BL-1513	15'	19'-11"	21'-6"	22'
BL-1613	16'	20'-11"	22'-6"	23'
BL-1713	17'	21'-11"	23'-6"	24'
BL-1813	18'	22'-11"	24'-6"	25'
BL-1913	19'	23'-11"	25'-6"	26'
BL-2013	20'	24'-11"	26'-6"	27'
BL-2113	21'	25'-11"	27'-6"	28'

- A: Raised Platform Height
- B: Centerline of Upper Rail
- C: Overall Max. Lift Height
- D\*: Min. Booth Height

*Note: All vertical dimensions shown are from the top of the lower rail*

Dimensions shown are nominal. Actual dimensions may vary and are presented with engineering drawings.



The BOOST® is a versatile self-propelled pneumatic elevating work platform. The BOOST® lift provides maneuverability, ergonomic positioning and added safety for the operator in hazardous environments where combustible dusts or vapors may be present.

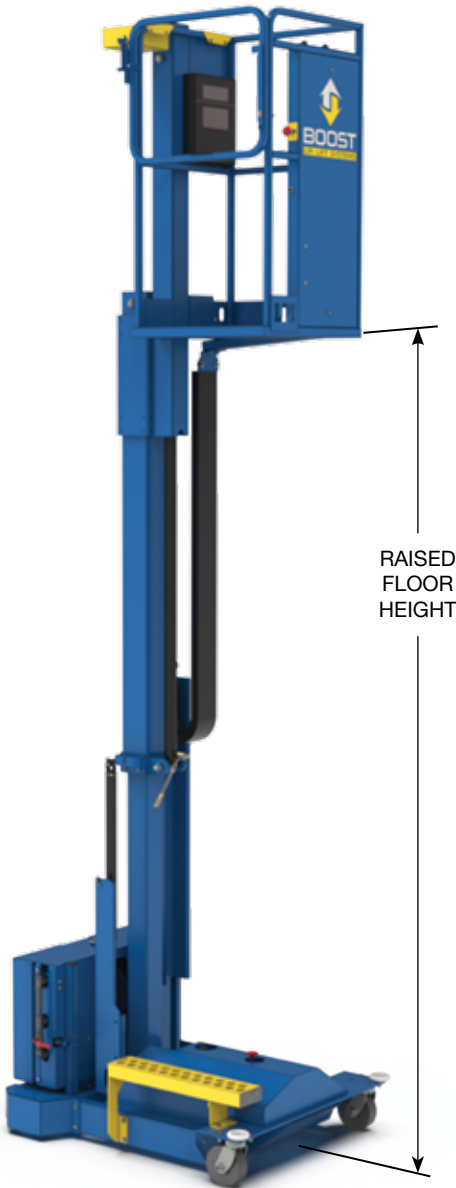

### GENERAL INFO

- Hose reel with up to 30 ft. operational travel distance
- Raised platform height: Up to 10'
- Minimum lowered platform height: 26"
- Single Operator Platform Capacity: 300 lbs.
- Platform Length x Width: 2' x 2'
- 43.5" high guard rail
- Pneumatic/Hydraulic power for hazardous areas
- Filter/Regulator/Lubricator
- Quick and easy connection to air source
- Front swivel casters

### CONTROLS / CONNECTIONS

- Primary air source connection: 3/8" hose with 3/8" NPT hose barb
- Auxiliary unooled air connection in platform: 3/8" NPT
- Lift requires a clean, dry air supply (40 scfm @ 90 psi with a 40°F dew point)
- Fixed hand control with Emergency stop
- Base emergency descent button

### TRAVEL SPEEDS

- X-Axis (left/right): Up to 40 fpm
- Z-Axis (up/down): Up to 15 fpm



BOOST® Series (Elevating Work Platform)				
Model	Raised Floor Ht.	Lowered Floor Ht.	Overall Length	Overall Width
BOOST®	10'	25"	4'-5"	3'-2"
-Slab type machines should only be raised on a hard, flat and level surface -Designed in accordance with applicable ANSI requirements based on machine configuration as originally manufactured for intended applications				

Due to continuous product improvement, LPI, Inc. reserves the right to make equipment/specification changes without prior notification.

**APPLICATIONS**

The BOOST® single operator lift is designed for use in hazardous or industrial areas where access is needed at elevated heights.

- Paint Booths
- Powder Coating Areas
- Paint Prep Areas
- Paint Kitchens
- Sanding/Buffering Areas
- Assembly
- Welding
- Maintenance
- Masking/Decal

Standard Options Available (Field Installed)	
Option Code	Description
1	Paint Pot Carrier Kit (Single, up to 3 gallon pot. Pot not included.)
2	Auxiliary Air Regulator with Gauge Kit
3	360° Swivel Air Connection Kit
4	Static Discharge Reel Kit
5	Paint Gun Hook Kit
6	Base Mount Parts/Tool Tray Kit
7	Front Platform Tool Tray Kit
8	Wide Wheel Drive Kit (Adds 4" to overall width)
9	Safety Auto-Shutoff Valve
10	Powder Residue Vacuum Carrier Kit (not shown)

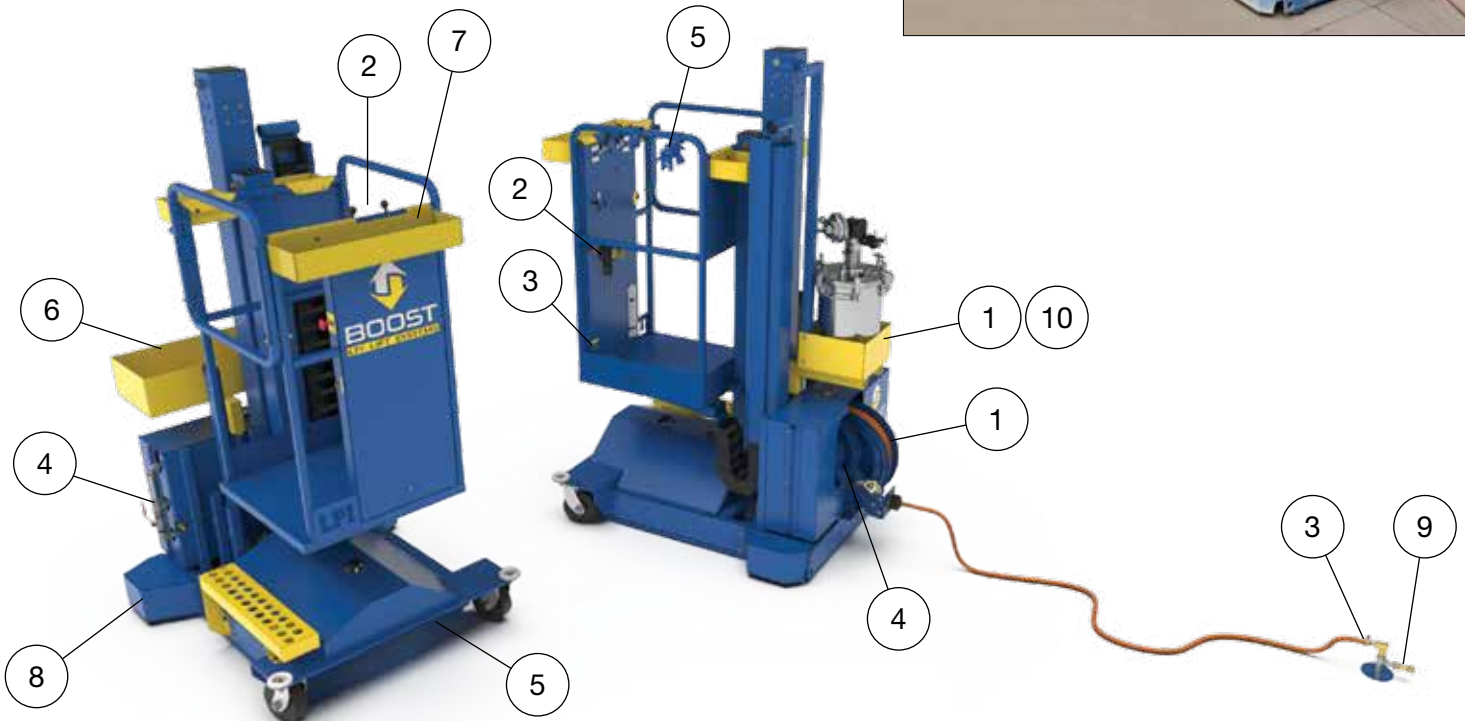

Dimensions shown are nominal. Actual dimensions may vary and are presented with engineering drawings.

## Single Axis Vertical Mast Lift

The VL Series is a turnkey, floor-mounted vertical mast work platform designed for permanent installation in surface finishing environments. Anchored in place for stability and repeatable positioning, the lift supports parallel workflow systems and conveyor-based processes where consistent vertical access is required. With a compact footprint and smooth vertical travel, the VL Series enables efficient, ergonomic operator access while reducing reliance on ladders and scaffolding in production settings.

### GENERAL INFO

- Raised platform height: Up to 10'
- Operator platform capacity: 300 lbs.
- Pneumatic/hydraulic power unit
- Includes in-line Filter/Regulator/Lubricator
- Operator Cab: 48" wide x 36" deep (standard)

### CONTROLS / CONNECTIONS

- Hand controls for Z-Axis & E-stop
- Base control to raise and lower platform
- Auxiliary unooled air connection in platform
- Lift requires a clean, dry air supply  
(50 scfm @ 90 psi with a 40°F dew point)

### TRAVEL SPEEDS

- Z-Axis (up/down): Up to 15 fpm



Platform is equipped with a removable front gate for easier part access if required.



Due to continuous product improvement, LPI, Inc. reserves the right to make equipment/specification changes without prior notification.

AVAILABLE OPTIONS

Breathing Air Option  
Breathing air supply connection point

Tool/Part Tray Option  
Tray to hold tools or supplies

Conveyor Interlock Option

Pneumatic switch provides an air signal for solenoid connection and conveyor control interlock, enabling conveyor operation.  
(Customer to supply all connections beyond the switch)

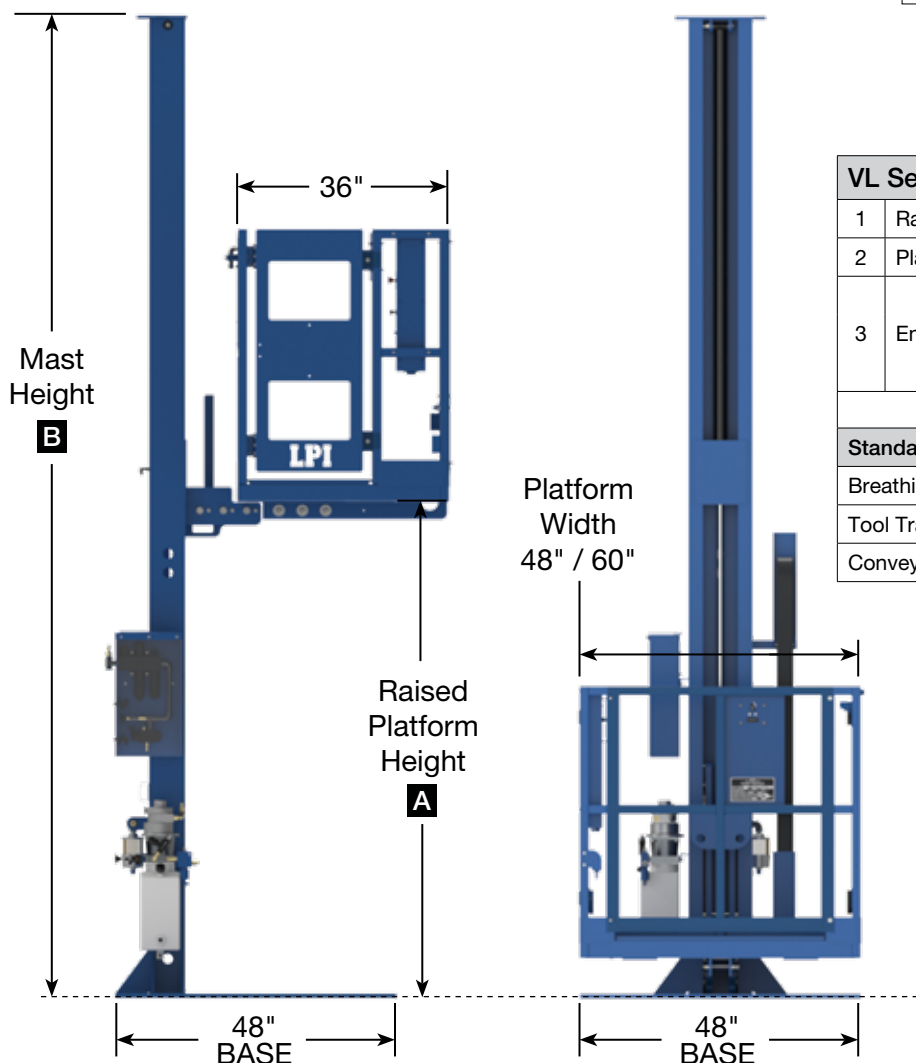
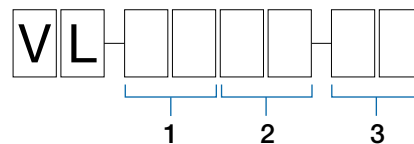
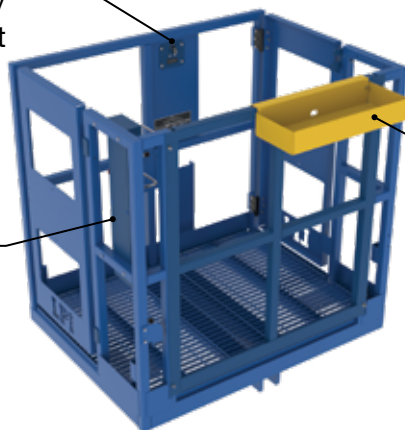

VL Series Standard Configurations		
1	Raised Platform Height (ft.)	06, 07, 08, 09, 10
2	Platform Width (in.)	48, 60
3	Entry Gate Location	LH (Left)
		RH (Right)
		BO (Both Sides)
Standard Options		
Breathing Air Connection on Platform		
Tool Tray		
Conveyor Interlock on Platform		

VL Series		
Model	A	B
VL06	5'-10"	12'
VL07	6'-10"	14'
VL08	7'-10"	16'
VL09	8'-10"	18'
VL10	9'-10"	20'

Dimensions shown are nominal. Actual dimensions may vary and are presented with engineering drawings.

The SPHR Series is a rail-guided, drivable scissor lift designed for safe, repeatable operator access in narrow paint and powder coating environments. Powered by a pneumatic-hydraulic system, the lift provides smooth vertical travel and is well suited for hazardous or industrial settings. The guided rail system allows controlled movement along a fixed path, making the SPHR ideal for tight spray booths, wet sanding, surface preparation, and finishing operations where consistent positioning is critical. With a stable platform and durable construction, the SPHR Series improves ergonomics, efficiency, and operator safety in demanding finishing applications.



### GENERAL INFO

- Raised platform height: 4'-5" to 12'
- Minimum lowered platform height: 14.5"
- Operator Platform Capacity: 500 lbs.
- Platform Dimensions: 66"L x 30"W
- 43.5" high guard rail with self-closing gate
- Pneumatic/Hydraulic power for hazardous areas
- Filter/Regulator/Lubricator
- Quick and easy connection to air source

### CONTROLS / CONNECTIONS

- Primary air source connection: 1/2" NPT
- Auxiliary uncoiled air connection in platform: 3/8" NPT
- Lift requires a clean, dry air supply  
(50 scfm @ 90 psi with a 40°F dew point)
- Fixed hand control with E-Stop
- Base control to raise and lower platform
- Optional pendant foot control to raise/lower platform

### TRAVEL SPEEDS

- X-Axis (left/right): Variable up to 40 fpm
- Z-Axis (up/down): Up to 15 fpm

Due to continuous product improvement, LPI, Inc. reserves the right to make equipment/specification changes without prior notification.



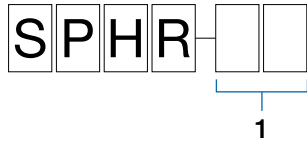

SPHR Series Standard Configurations		
1	Raised Platform Height	04 (4 Ft)
		08 (8 Ft)
		12 (12 Ft)
Standard Options		
	Foot Control Pendant (Horizontal Travel)	FC
	Tool Tray	TT



Hose Reel Festooning



Overhead Festooning



SPHR Series (Rail Guided Lift Systems)				
Model	A	B	Overall Length	Overall Width
SPHR-04	4'-5"	1'-2.5"	6'-8"	3'-3"
SPHR-08	8'	1'-10"		
SPHR-12	12'	2'		

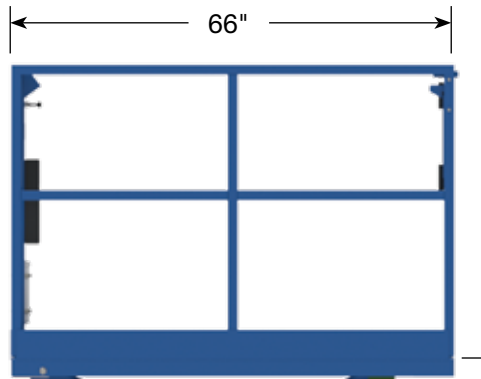

Optional Foot Operated Travel Pendant

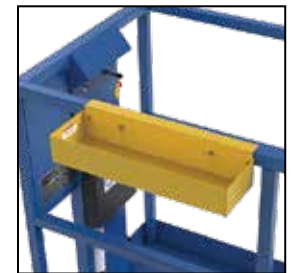

Optional Bolt-on Tool Tray

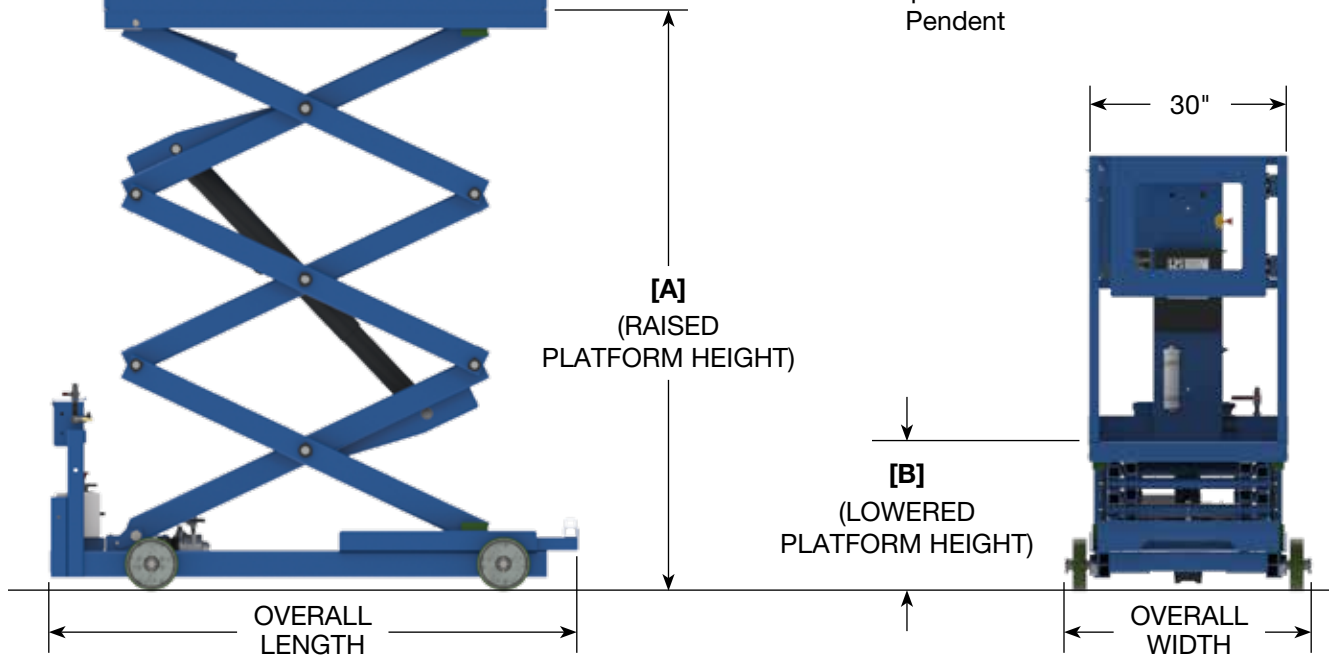

Dimensions shown are nominal. Actual dimensions may vary and are presented with engineering drawings.

The WCL Series is a manually positioned scissor lift designed to provide safe, ergonomic access at height while replacing ladders and scaffolding in industrial environments. The lift features integrated manual roll-out platform extensions on both ends, allowing operators to position themselves closer to the work area for improved reach and efficiency. A raised base design provides added clearance around floor-level obstructions, equipment, or fixtures. Its stable scissor design and durable construction make it well suited for manufacturing, fabrication, and assembly operations where repeatable access and operator safety are critical.

### GENERAL INFO

- Raised platform height: Up to 10'
- Lowered platform height: 3'-9"
- Extended dimension: 16'-6"
- Operator platform capacity: 1,500 lbs.
- Rollout section capacity: 300 lbs.
- Pneumatic/hydraulic power unit
- Includes in-line Filter/Regulator/Lubricator
- Platform (condensed): 10'-3" x 35"
- Self closing/latching entry gate
- Caster wheel options available
- Optional entry gates on end of rollouts

### CONTROLS / CONNECTIONS

- Hand controls for Z-Axis travel
- Base control to raise and lower platform
- Emergency descent button on base
- Auxiliary uncoiled air connection in platform
- Lift requires a clean, dry air supply (50 scfm @ 90 psi with a 40°F dew point)

### TRAVEL SPEEDS

- Z-Axis (up/down): Up to 15 fpm



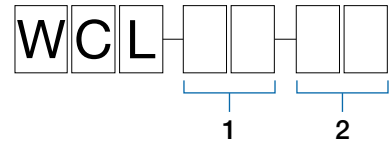

WCL Series Standard Configurations		
1	Roll-out Gates	NG (No Roll-out End Gates) RG (Roll-out End Gates)
2	Casters	EC (8" Casters) TC (10" Casters) EP (8" Poly Casters)

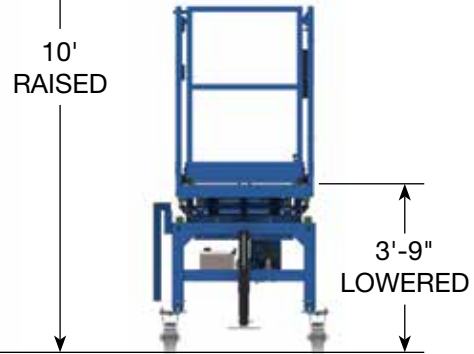
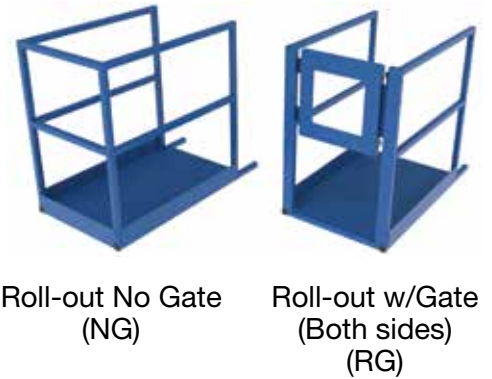
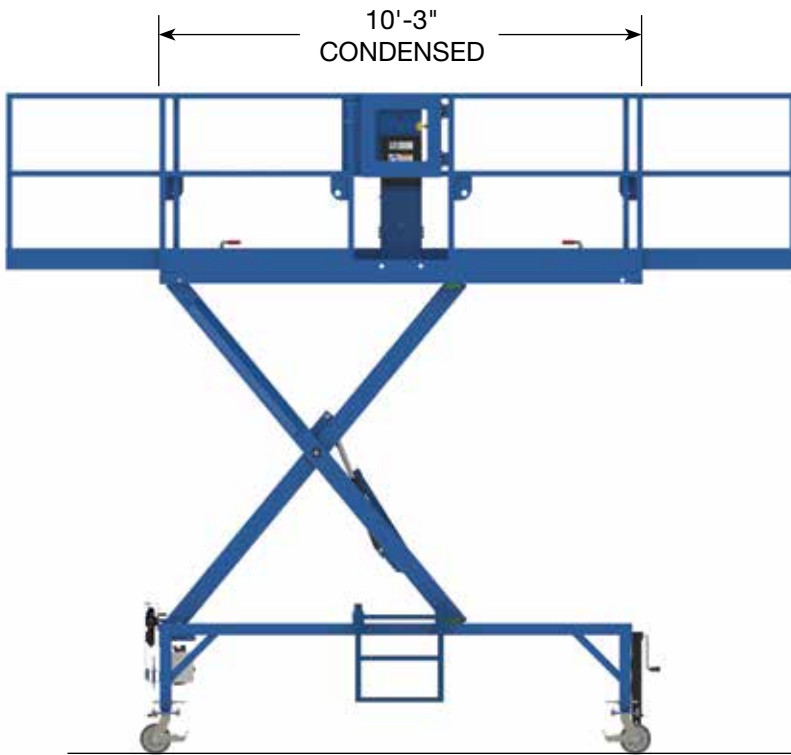

Dimensions shown are nominal. Actual dimensions may vary and are presented with engineering drawings.



### SCISSOR LIFTS & WORK PLATFORMS

Scissor Lifts and Work Platforms are cost effective solutions for positioning workers where the work environment requires flexibility in the process or task. Scissor Lifts and Work Platforms offer vertical travel and horizontal floor travel. Options include:

- Rail-Guided Floor Travel
- Manual Positioning
- Platform Roll-Outs / Extensions
- Hand & Foot Control Options
- Pneumatic / Hydraulic Power Units
- Electric / Hydraulic Power Units



### CUSTOM LIFTS

LPI offers fully customized lift solutions that are designed and built specifically for your application. Custom lifts can be designed to accommodate several personnel, unique environments, process equipment and varying applications. LPI engineers can provide custom solutions from small to large scale designs.



Custom Rail-Guided Work Platform with Roll-Out Extensions



Overhead Lift System with Drop-Down Platform



Custom Material Handling / Material Picking Lift

# WARRANTY & SERVICES

## STANDARD SERVICES & MAINTENANCE

LPI, Inc. prides itself on excellent customer service. Our sales, engineering and customer service staff actively ensure our customers are taken care of from initial contact through the project build, delivery and installation. LPI also offers maintenance, training and service support to ensure proper safe operation after installation and throughout the entire product life cycle.

### WARRANTY

LPI is known for its quality, robust designs and we stand behind our products. LPI offers a 12 month warranty on materials and workmanship from the date the order is shipped. For full warranty details, scan the QR code or visit: <https://www.lpi-inc.com/warranty>



### INSTALLATION & TRAINING

LPI offers trained technicians to help guide and assist in the installation of lifts. Consult with a member of the sales team to discuss what level of installation or training assistance would be needed for your application.



### SERVICE / MAINTENANCE / PARTS

Properly maintained LPI lifts provide many years of reliable service. Delayed or neglected maintenance can reduce the life of components and affect the performance of the lift leading to failures and operational downtime. LPI's Service Technicians offer annual inspections and on site maintenance service plans and training to help ensure your lift equipment is running at peak performance.

LPI has many plans and services available that may best suit your needs.

- Scheduled maintenance plans
- Annual on-site safety inspections
- On-site repair / rebuild services
- Operator training
- Replacement parts



To schedule service, maintenance, installation or training, please email our Customer Service department:

[customerservice@lpi-inc.com](mailto:customerservice@lpi-inc.com)

**Elevating Safety.  
Engineering Confidence.**

**[www.lpi-inc.com](http://www.lpi-inc.com)**

**LPI**<sup>®</sup>  
**LIFT SYSTEMS**



**Eau Claire, WI USA  
1-800-657-6956  
[www.lpi-inc.com](http://www.lpi-inc.com)  
[sales@lpi-inc.com](mailto:sales@lpi-inc.com)**

L-1145 | APR2026